

# OBIS LX SF - SINGLE FREQUENCY

## Narrow Linewidth, Single Longitudinal Mode Lasers

OBIS lasers now with single frequency, narrow linewidth in 405 nm, 633 nm, 660 nm, and 785 nm. These are direct diode laser modules with an internal Volume Holographic Grating (VHG) to create a single frequency, long coherence length laser.

OBIS LX SF is an ideal source for demanding 405 nm single longitudinal mode (SLM) applications. OBIS LX SF at 632.8 nm (633 nm) can replace stabilized Helium Neon (HeNe) lasers.

OBIS offers excellent beam quality combined with extremely low RMS Noise. High signal and low noise gives your application exceptional signal-to-noise ratio (SNR).



### FEATURES AND BENEFITS

- Commonality across the spectrum in OBIS LX/LS
- Single frequency, narrow linewidth
- Collimated TEM<sub>00</sub> circular beam output
- Long coherence length of ~1 meter
- Integrated control electronics

### APPLICATIONS

- Raman Spectroscopy
- Interferometry
- HeNe (Helium Neon) Replacement
- Holography
- Medical Imaging and Instrumentation
- Metrology
- Bio-instrumentation
- Particle Characterization
- Industrial Gas Sensing

## OBIS LX SF - SINGLE FREQUENCY

Specifications	OBIS 405 nm LX SF 40 mW	OBIS 633 nm LX SF 50 mW	OBIS 660 nm LX SF 35 mW	OBIS 785 nm LX SF 50 mW
Wavelength <sup>1</sup> (nm)	405	633	660	785
Linewidth (MHz) (typical)	160	150	300	50
Linewidth (pm) (maximum)	0.4	0.3	1.5	0.7
Spectral Purity (SMSR) (typical) (dB)	40	40	40	40
Output Power <sup>2</sup> (mW)	40	50	35	50
Spatial Mode	TEM <sub>00</sub>	TEM <sub>00</sub>	TEM <sub>00</sub>	TEM <sub>00</sub>
M <sup>2</sup> (Beam Quality) <sup>3</sup>	≤1.8	≤1.3	≤1.4	≤1.5
Beam Asymmetry	≤1:1.2	≤1:1.2	≤1:1.2	≤1:1.2
Beam Diameter at 1/e <sup>2</sup> (mm)	0.4 ±0.1	0.5 ±0.1	1.1 ±0.3	0.85 ±0.1
Beam Divergence (mrad, full-angle)	<2.2	<2.2	<1.7	<2
Pointing Stability (μrad) (over 2 hours after warm-up and ±3°C)	<30	<30	<30	<30
Pointing Stability Over Temp. (μrad/°C)	<5	<5	<5	<5
RMS Noise <sup>4</sup> (%) (20 Hz to 20 MHz)	≤0.05	≤0.05	≤0.05	≤0.05
Peak-to-Peak Noise <sup>4</sup> (%) (20 Hz to 20 kHz)	<0.5	<0.5	<0.5	<0.5
Long-term Wavelength Stability (pm) (8 hrs., ±2°C) typical	<2	<3	<10	<10
Long-term Power Stability (%) (8 hrs., ±3°C)	<1	<1	<1	<1
Warm-up Time <sup>5</sup> (minutes) (from cold start)	<5	<5	<5	<5
Polarization Ratio	Minimum 100:1, Vertical ±5°			
Laser Drive Modes	CW: Current and Computer Control			
Static Alignment Tolerances				
Beam Position from Reference <sup>6</sup> (mm)	<1	<1	<1	<1
Beam Angle <sup>5</sup> (mrad)	<5	<5	<5	<5

Notes:

1. Measured as an Air reference. Laser-to-laser wavelength tolerance ±1 nm for all OBIS LX SF versions, except OBIS 633 nm LX SF with a wavelength tolerance of 632.8 ±0.5 nm.
2. Output power is variable in CW Mode from 1 mW (1% for LX Models) to 110% of rated power. Specifications are valid for 100% power.
3. M<sup>2</sup> measured with ModeMaster with 90/10 clip levels.
4. RMS Noise and Peak-to-Peak Noise measured in Constant Current mode.
5. Typical power-on delay to reach output power in 0.1 minutes.
6. See mechanical drawing for exit beam location.

## OBIS LX SF - SINGLE FREQUENCY

Specifications	OBIS 405 nm LX SF 40 mW	OBIS 633 nm LX SF 50 mW	OBIS 660 nm LX SF 35 mW	OBIS 785 nm LX SF 50 mW
Laser Safety Classification	3b	3b	3b	3b
ESD Protection	EN61326-1	EN61326-1	EN61326-1	EN61326-1
Power Consumption (W)	Typical 5, Max. 13	Typical 5, Max. 13	Typical 5, Max. 13	Typical 5, Max. 13
Laser Head Baseplate Temp. (maximum, °C)	50	50	50	50
Heat Dissipation of Laser Head <sup>1</sup> (W)	Typical 5, Max. 13	Typical 5, Max. 13	Typical 5, Max. 13	Typical 5, Max. 13
Ambient Temperature <sup>2</sup> Operating Condition (°C) Non-operating Condition (°C)	10 to 50 -20 to 60	10 to 50 -20 to 60	10 to 50 -20 to 60	10 to 50 -20 to 60
Shock Tolerance (g) (6 ms)	30	30	30	30
Laser Part Number	1448284	1448283	1447430	2253321
Laser System Part Number (includes laser, remote, power supply, cables)	1448286	1448288	1448287	2253466
OBIS LX/LS Heat Sink with Fan (sold separately)	1193289			

**Notes:**





1. Typically 85% of heat load through the base plate. See Users Manual for more detail.
2. Non-Condensing. See User Manual for more detail.



Utility and Environmental Requirements	
Operating Voltage <sup>1</sup> (VDC)	12 ±2
Dimensions (L x W x H) Laser OBIS Remote (optional) DC Power Supply (optional) Cable, Laser to OBIS Remote (optional)	70 x 40 x 38 mm (2.75 x 1.57 x 1.5 in.) 105 x 68 x 36 mm (4.13 x 2.68 x 1.42 in.) 105 x 42 x 33 mm (4.13 x 1.65 x 1.3 in.) 1 meter (3.28 ft.) (3 meter and 0.3 meter sold separately)
Weight Laser OBIS Remote (optional) DC Power Supply (optional) Cable, Laser to OBIS Remote (optional)	0.16 kg (0.35 lbs.) 0.24 kg (0.53 lbs.) 0.36 kg (0.79 lbs.) 0.1 kg (0.22 lbs.) for 1 meter

**Notes:**

1. If user supplied, the DC power supply has to meet the following requirements: power >20 W; ripple <5% peak-to-peak; line regulation <0.5%.

## OBIS LX SF - SINGLE FREQUENCY

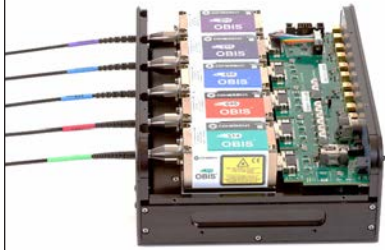
Optional OBIS Laser Accessories	Description
	<p>OBIS Heat Sink with fan for thermal management, includes hardware to mount to table. Laser can be mounted on top or side for horizontal polarization. Convenient 69 mm (2.7 inch) beam height.</p> <p>Part Number 1193289 OBIS Heat Sink Mount.</p>
	<p>OBIS LX/LS Single Laser Remote with full features for control with Analog and Digital modulation inputs. Includes USB and RS-232 connectors on the back panel of the Remote.</p> <p>Part Number 1214875 OBIS LX/LS Single Laser Remote, with Power Supply, 1 meter laser-to-remote (SDR) cable, USB cable, and Coherent Connection applications software.</p> <p>Part Number 1173961 OBIS LX/LS Single Laser Remote, with Power Supply, USB cable, and Coherent Connection applications software (no SDR Laser-to-Remote cable).</p>
	<p>OBIS LX/LS 6-Laser Remote with CDRH features. Separate power switches and power cables for each laser. NOTE: Does not support modulation inputs.</p> <p>Part Number 1203909 OBIS LX/LS 6-Laser Remote, with Power Supply, 6 power cables from laser-to-remote, and Coherent Connection applications software.</p> <p>Part Number 1306263 OBIS LX/LS 6-Laser Remote, with Power Supply and Coherent Connection applications software (no laser-to-remote power cables).</p>
	<p>OBIS LX/LS Scientific Remote with full features for control with analog/digital inputs for up to six lasers. User interface touch screen and connectivity through USB, RS-232, and Ethernet.</p> <p>Part Number 1234466 OBIS LX/LS Scientific Remote, with internal Power Supply, 6 laser-to-remote (SDR) cables, and Coherent Connection applications software.</p> <p>Part Number 1234465 OBIS LX/LS Scientific Remote, with internal Power Supply, and Coherent Connection applications software (no SDR Laser-to-Remote cables).</p> <p>NOTE: OBIS LX/LS Scientific Remote is not compatible with OBIS LX SF.</p>

Optional OBIS Laser Accessories	Description
	<p>OBIS LX/LS Laser Box with five laser mounting bays with thermal management, cooling fans, analog/digital inputs, RS-232, USB, key-switch, and interlock in one compact package. Lasers sold separately.</p> <p>Part Number 1228877 OBIS LX/LS Laser Box, with Power Supply, USB cable, and Coherent Connection applications software. Analog Modulation Impedance = 2k <math>\Omega</math>, Digital Modulation Impedance = 50 <math>\Omega</math>.</p> <p>Part Number 1343229 OBIS LX/LS Laser Box, with Power Supply, USB cable, and Coherent Connection applications software. Analog Modulation Impedance = 2k <math>\Omega</math>, Digital Modulation Impedance = 2k <math>\Omega</math>.</p>
	<p>OBIS LX ASE Filter can reduce noise in applications that are sensitive to shorter or longer wavelength emissions.</p> <p>OBIS LX ASE Filter conveniently threads into the front of the OBIS LX laser to remove wavelength emissions outside the laser line. Bandpass filter is specifically mounted to avoid internal retro-reflection from the filter.</p> <p>Part Number 2253957 ASE Filter, 405nm OBIS SF          Transmission of &gt; 90% at 405 nm          Blocking Band OD&gt;5 at 354 to 401 nm          Blocking Band OD&gt;6 at 373 to 398 nm          Blocking Band OD&gt;6 at 412 to 445 nm          Blocking Band OD&gt;5 at 410 to 495 nm</p> <p>Part Number 2253959 ASE Filter, 633 nm OBIS SF          Transmission of &gt; 90% at 633 nm          Blocking Band OD&gt;5 at 515 to 626nm          Blocking Band OD&gt;6 at 583 to 623 nm          Blocking Band OD&gt;6 at 643 to 696 nm          Blocking Band OD&gt;5 at 640 to 884 nm</p> <p>Part Number 2254008 ASE Filter, 785 nm OBIS SF          Transmission of &gt; 90% at 785 nm          Blocking Band OD&gt;5 at 613 to 777 nm          Blocking Band OD&gt;6 at 723 to 773 nm          Blocking Band OD&gt;6 at 797 to 863 nm          Blocking Band OD&gt;5 at 793 to 1213 nm</p>

# OBIS LX SF - SINGLE FREQUENCY

## Mechanical Specifications

View of Filter Installed on Laser  
(Laser Sold Separately)

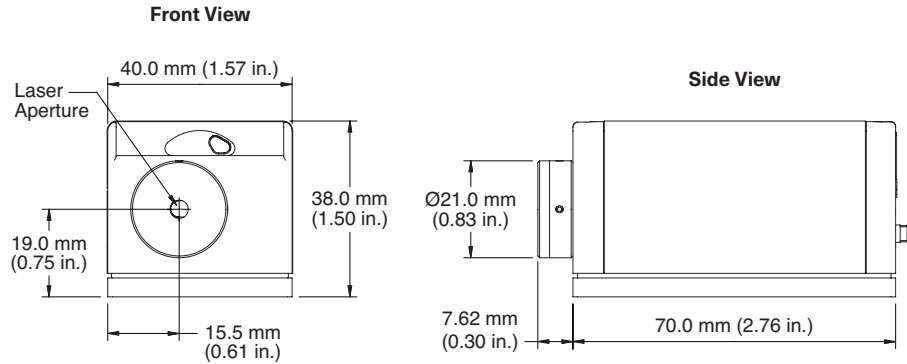

OBIS LX SF

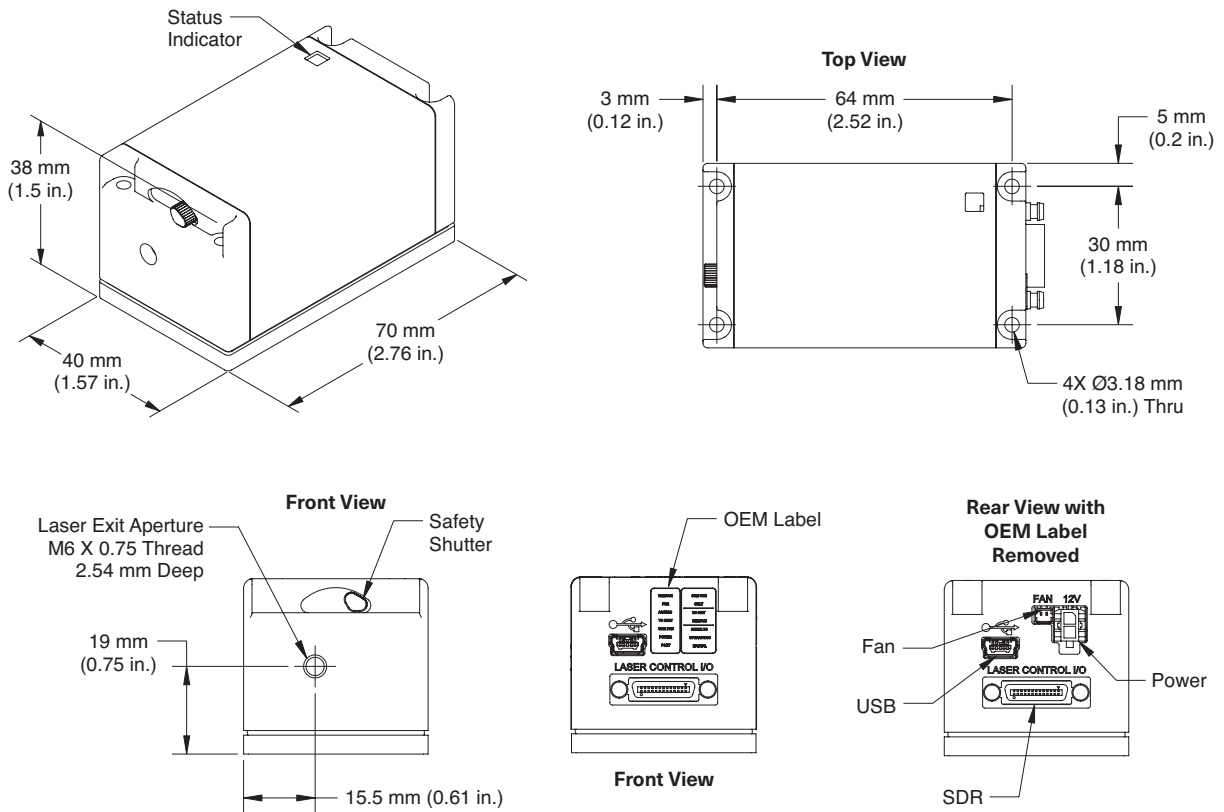

# OBIS LX SINGLE FREQUENCY FP

## Fiber Pigtailed Lasers in a Plug-and-Play Platform

The OBIS LX Single Frequency Fiber Pigtailed (OBIS FP) suite of lasers delivers the simplicity of a plug-and-play platform for a wide range of wavelengths from the violet to the near IR. The fiber pigtail termination is complete with a FC/APC connector. The OBIS LX Single Frequency FP lasers are based on the OBIS LX Single Frequency laser platform, offering the same speed-to-market benefits.

The OBIS LX Single Frequency FP lasers offer superior performance, reliability, and hands-free operation. These lasers combine single-mode polarization maintaining fiber with an FC/APC connector for a high-quality low-noise laser beam output. They utilize proprietary fiber technology to provide superior lifetimes, and permanent fiber attachments for guaranteed power over time.



### FEATURES AND BENEFITS

- All OBIS advantages with fiber delivery
- Single mode, polarization maintaining fiber
- Extended life fiber design

### APPLICATIONS

- Raman Spectroscopy
- Interferometry
- HeNe (Helium Neon) Replacement
- Holography
- Medical Imaging and Instrumentation
- Metrology
- Bio-instrumentation
- Particle Characterization
- Industrial Gas Sensing

## OBIS LX SF FIBER-PIGTAILED - SINGLE FREQUENCY

Specifications	OBIS 405 nm LX SF FP 20 mW	OBIS 633 nm LX SF FP 30 mW	OBIS 660 nm LX SF FP 25 mW	OBIS 785 nm LX SF FP 40 mW
Wavelength <sup>1</sup> (nm)	405	633	660	785
Linewidth (MHz) (typical)	160	150	300	50
Linewidth (pm) (maximum)	0.4	0.3	1.5	0.7
Spectral Purity (SMSR) (typical) (dB)	40	40	40	40
Output Power <sup>2</sup> (mW)	20	30	25	40
Output from Fiber	FC/APC; 8° angled <sup>7</sup>	FC/APC; 8° angled	FC/APC; 8° angled	FC/APC; 8° angled
Fiber Cable Type	3 mm Mono-Coil	3 mm Mono-Coil	3 mm Mono-Coil	3 mm Mono-Coil
Fiber Cable Length (m) (minimum)	1	1	1	1
Fiber Numerical Aperture (NA) (1/e <sup>2</sup> )	0.05	0.09	0.09	0.12
Fiber Core Diameter (μm) (typical)	3.5	4.5	4.5	4.5
Spatial Mode	TEM <sub>00</sub>	TEM <sub>00</sub>	TEM <sub>00</sub>	TEM <sub>00</sub>
M <sup>2</sup> (Beam Quality) <sup>3</sup>	≤1.1	≤1.1	≤1.1	≤1.1
Beam Asymmetry	≤1:1.1	≤1:1.1	≤1:1.1	≤1:1.1
RMS Noise <sup>4</sup> (%) (20 Hz to 20 MHz)	≤0.05	≤0.05	≤0.05	≤0.05
Peak-to-Peak Noise <sup>4</sup> (%) (20 Hz to 20 kHz)	<0.5	<0.5	<0.5	<0.5
Long-term Wavelength Stability (pm) (8 hrs., ±2°C) typical	<2	<3	<10	<10
Long-term Power Stability (%) (8 hrs., ±3°C)	<1	<1	<1	<1
Warm-up Time <sup>5</sup> (minutes) (from cold start)	<5	<5	<5	<5
Polarization Ratio	Minimum 100:1, Vertical ±5°			
Laser Drive Modes	CW: Current and Computer Control			
Static Alignment Tolerances				
Beam Position from Reference <sup>6</sup> (mm)	<1	<1	<1	<1
Beam Angle <sup>5</sup> (mrad)	<5	<5	<5	<5

**Notes:**

1. Measured as an Air reference. Laser-to-laser wavelength tolerance ±1 nm for all OBIS LX SF versions, except OBIS 633 nm LX SF with a wavelength tolerance of 632.8 ±0.5 nm.
2. Output power is variable in CW Mode from 1 mW (1% for LX Models) to 110% of rated power. Specifications are valid for 100% power.
3. M<sup>2</sup> measured with ModeMaster with 90/10 clip levels.
4. RMS Noise and Peak-to-Peak Noise measured in Constant Current mode.
5. Typical power-on delay to reach output power in 0.1 minutes.
6. See mechanical drawing for exit beam location.
7. Fiber FC/APC connector output not compatible for patchcord-to-patchcord connection.

## OBIS LX SF FIBER-PIGTAILED - SINGLE FREQUENCY

Specifications	OBIS 405 nm LX SF FP 20 mW	OBIS 633 nm LX SF FP 30 mW	OBIS 660 nm LX SF FP 25 mW	OBIS 785 nm LX SF FP 40 mW
Laser Safety Classification	3b	3b	3b	3b
ESD Protection	EN61326-1	EN61326-1	EN61326-1	EN61326-1
Power Consumption (W)	Typical 5, Max. 13	Typical 5, Max. 13	Typical 5, Max. 13	Typical 5, Max. 13
Laser Head Baseplate Temp. (maximum, °C)	50	50	50	50
Heat Dissipation of Laser Head <sup>1</sup> (W)	Typical 5, Max. 13	Typical 5, Max. 13	Typical 5, Max. 13	Typical 5, Max. 13
Ambient Temperature <sup>2</sup> Operating Condition (°C) Non-operating Condition (°C)	10 to 50 -20 to 60	10 to 50 -20 to 60	10 to 50 -20 to 60	10 to 50 -20 to 60
Shock Tolerance (g) (6 ms)	30	30	30	30
Laser Part Number	2278596	2278601	2285213	2278533
Laser System Part Number (includes laser, remote, power supply, cables)	2282412	2282413	2285287	2282411
OBIS LX/LS Heat Sink with Fan (sold separately)	1193289			

**Notes:**

1. Typically 85% of heat load through the base plate. See Users Manual for more detail.
2. Non-Condensing. See User Manual for more detail.

Utility and Environmental Requirements	
Operating Voltage <sup>1</sup> (VDC)	12 ±2
Dimensions (L x W x H) Laser OBIS Remote (optional) DC Power Supply (optional) Cable, Laser to OBIS Remote (optional) Fiber Minimum Bend Radius	70 x 40 x 38 mm (2.75 x 1.57 x 1.5 in.) 105 x 68 x 36 mm (4.13 x 2.68 x 1.42 in.) 105 x 42 x 33 mm (4.13 x 1.65 x 1.3 in.) 1 meter (3.28 ft.) (3 meter and 0.3 meter sold separately) 51 mm (2.0 in.)
Weight Laser OBIS Remote (optional) DC Power Supply (optional) Cable, Laser to OBIS Remote (optional) Fiber Tensile Load (max.)	0.16 kg (0.35 lbs.) 0.24 kg (0.53 lbs.) 0.36 kg (0.79 lbs.) 0.1 kg (0.22 lbs.) for 1 meter 1 kg (2.2 lbs.)

**Notes:**

1. If user supplied, the DC power supply has to meet the following requirements: power >20 W; ripple <5% peak-to-peak; line regulation <0.5%.



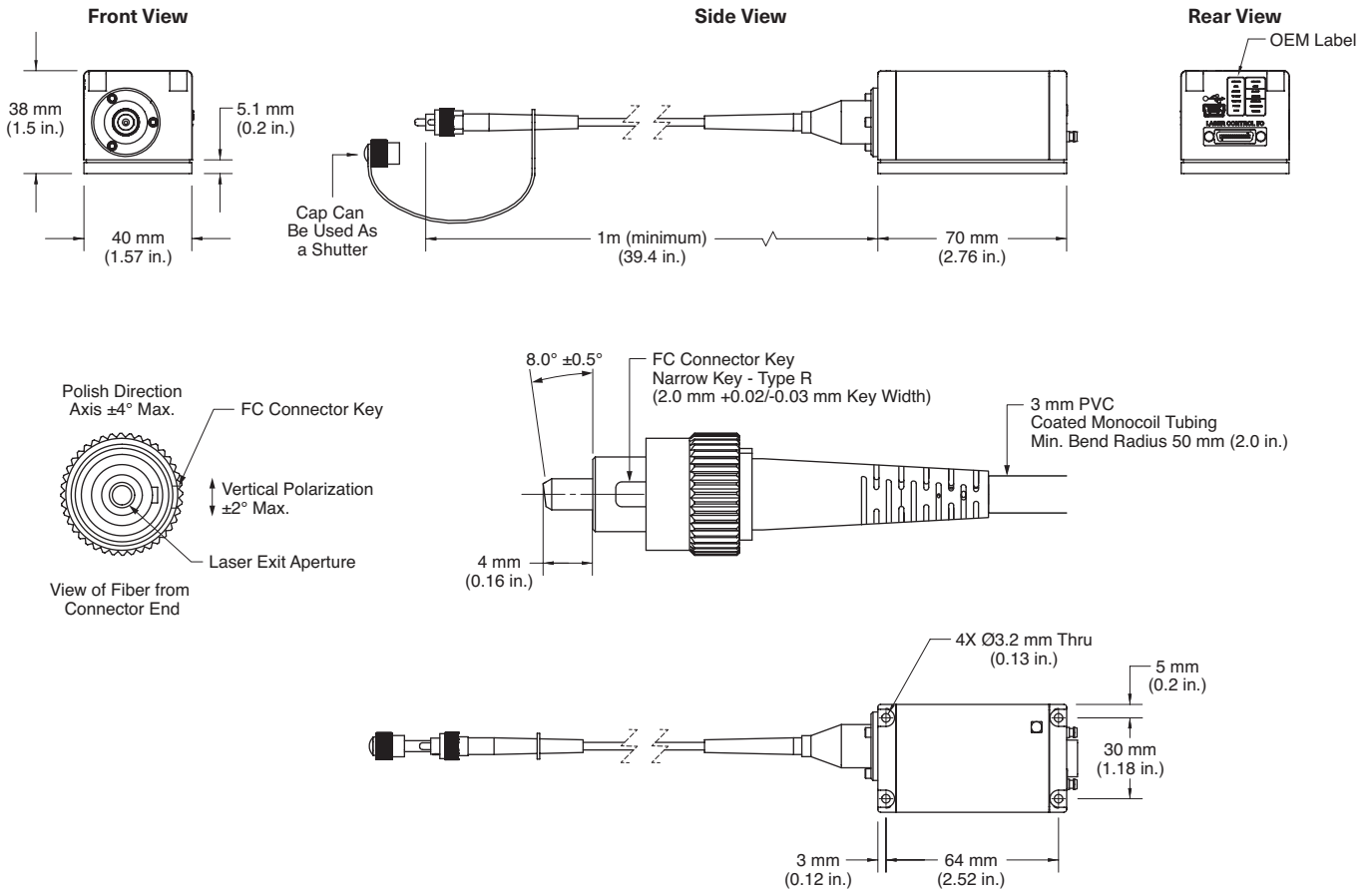

# OBIS LX SF FIBER-PIGTAILED - SINGLE FREQUENCY

## Mechanical Specifications



OBIS LX SF FP



## OBIS LX SF FIBER-PIGTAILED - SINGLE FREQUENCY

Optional OBIS Laser Accessories	Description
	<p>OBIS Heat Sink with fan for thermal management, includes hardware to mount to table. Laser can be mounted on top or side for horizontal polarization. Convenient 69 mm (2.7 inch) beam height.</p> <p>Part Number 1193289 OBIS Heat Sink Mount.</p>
	<p>OBIS LX/LS Single Laser Remote with full features for control with Analog and Digital modulation inputs. Includes USB and RS-232 connectors on the back panel of the Remote.</p> <p>Part Number 1214875 OBIS LX/LS Single Laser Remote, with Power Supply, 1 meter laser-to-remote (SDR) cable, USB cable, and Coherent Connection applications software.</p> <p>Part Number 1173961 OBIS LX/LS Single Laser Remote, with Power Supply, USB cable, and Coherent Connection applications software (no SDR Laser-to-Remote cable).</p>
	<p>OBIS LX/LS 6-Laser Remote with CDRH features. Separate power switches and power cables for each laser. NOTE: Does not support modulation inputs.</p> <p>Part Number 1203909 OBIS LX/LS 6-Laser Remote, with Power Supply, 6 power cables from laser-to-remote, and Coherent Connection applications software.</p> <p>Part Number 1306263 OBIS LX/LS 6-Laser Remote, with Power Supply and Coherent Connection applications software (no laser-to-remote power cables).</p>
	<p>OBIS LX/LS Scientific Remote with full features for control with analog/digital inputs for up to six lasers. User interface touch screen and connectivity through USB, RS-232, and Ethernet.</p> <p>Part Number 1234466 OBIS LX/LS Scientific Remote, with internal Power Supply, 6 laser-to-remote (SDR) cables, and Coherent Connection applications software.</p> <p>Part Number 1234465 OBIS LX/LS Scientific Remote, with internal Power Supply, and Coherent Connection applications software (no SDR Laser-to-Remote cables).</p> <p>NOTE: OBIS LX/LS Scientific Remote is not compatible with OBIS LX SF.</p>

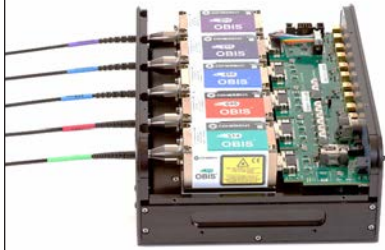
## OBIS LX SF FIBER-PIGTAILED - SINGLE FREQUENCY

Optional OBIS Laser Accessories	Description
	<p>OBIS LX/LS Laser Box with five laser mounting bays with thermal management, cooling fans, analog/digital inputs, RS-232, USB, key-switch, and interlock in one compact package. Lasers sold separately.</p> <p>Part Number 1228877 OBIS LX/LS Laser Box, with Power Supply, USB cable, and Coherent Connection applications software. Analog Modulation Impedance = 2k <math>\Omega</math>, Digital Modulation Impedance = 50 <math>\Omega</math>.</p> <p>Part Number 1343229 OBIS LX/LS Laser Box, with Power Supply, USB cable, and Coherent Connection applications software. Analog Modulation Impedance = 2k <math>\Omega</math>, Digital Modulation Impedance = 2k <math>\Omega</math>.</p>
	<p>OBIS LX/LS Modulation Interface, Analog and Digital Modulation, SDR. Compact board-level Modulation Interface. SMB connector for Analog Modulation control input. SMB Connector for Digital Modulation control input. Plugs directly into OBIS laser.</p> <p>Part Number 1319290 OBIS LX/LS Modulation Interface, Analog and Digital Modulation, SDR. Compact and easy-to-use, this OBIS Modulation Interface offers separate SMB input for Analog and Digital Modulation. This accessory works with all OBIS LS and LX lasers.</p> <p>Details: Modulation Interface plugs directly into the OBIS Laser. Analog Modulation can be set for a 50 <math>\Omega</math> or 2K <math>\Omega</math> input impedance. Digital Modulation can be set for a 50 <math>\Omega</math> or 2K <math>\Omega</math> input impedance. Digital Modulation can also be set to operate with Laser ON at 3.3 Volts or Laser ON at 5 Volts. Modulation interface must be connected to the OBIS Power Supply, sold separately to then power the interface and laser together. Dimensions (W x H x L): 40 x 20 x 120 mm (with laser).</p>