

OBIS Galaxy

8-Laser Beam Combiner

OBIS Galaxy is offering plug-and-play capabilities in laser combining.

The OBIS Galaxy is equipped with 8 FC fiber inputs, and can accept any Galaxy compatible laser using a plug-and-play integration. Each input is optimized to accept the fiber with a FC connection, and Coherent's patented beam combining technology integrates all 8 inputs.

The OBIS Galaxy provides a fiber output of the combined 8 lasers in a single-mode polarization-maintaining fiber, 2 meters in length, with a FC connector for any application.

The OBIS Galaxy matches Coherent's rigorous standards and advanced stress-testing benchmarks, offering the ease of integration, robustness, superior performance, and reliability.



FEATURES

- Plug-and-play 8-input, single-output beam combiner
- Compact and low profile
- High transmission beam combiner with typical 60% throughput per channel
- Fiber FC/APC output connector;
- FC/PC8 output connector available as an option

APPLICATIONS

- Optogenetics
- Endoscopy
- Spinning Disk and TIRF Microscopy
- Cytometry
- Genomics

Specifications ¹	OBIS Galaxy Laser Combiner
8 Input Fiber Connections ² (nm)	405 445 or 458 488 or 473 514 532 561 594 640
Power Throughput ³ (%) (when used with Coherent OBIS Galaxy Compatible Lasers) for 405 nm to 594 nm for 640 nm	>45, Typical >60 >55, Typical >70
Maximum Power Per Channel (mW)	120
Maximum Total Output Power (mW)	<500
RMS Noise (%) (20 Hz to 2 MHz)	<0.5
Peak-to-Peak Noise (%) (20 Hz to 20 kHz)	<2
Fiber Connector Type (Input Connectors)	FC form-factor, ultra-flat contact FC/UFC with extended-life interface, anti-reflection (AR) coated tip
Polarization Extinction Ratio Loss (%)	<50
Long-Term Power Throughput (%) (8 hours, ±3°C)	>95
Long-Term Power Throughput (%) (average)	≤2 over 1000 hours
Output Fiber	
Fiber Connector Type ⁴ (distal end) FC/APC Optional FC/PC8	8° angled, with extended-life interface 8° angled, with extended-life interface
Fiber Cable Type	3 mm mono-coil
Fiber Cable Length (m) (minimum)	2
Fiber Numerical Aperture (NA) (1/e ²) FC/APC Optional FC/PC8	0.055 0.065
Mode Field Diameter (μm) (typical)	3
Spatial Mode	TEM00
M ² (Beam Quality) ⁵	≤1.1
Fiber Minimum Bend Radius	51 mm (2.0 in.)
Fiber Tensile Load (maximum)	1 kg (2.2 lbs.)

Notes:

- System specifications measured at 25°C.
- All input channels require a ±1 nm center wavelength tolerance. Required wavelength tolerances specifically: 405 nm with 404 nm to 406 nm, 445 nm with 444 nm to 446 nm, 458 nm with 457 nm to 459 nm, 488 nm with 487 nm to 489 nm, 514 nm with 513 nm to 515 nm, 532 nm with 531 nm to 533 nm, 561 nm with 560.5 nm to 562.5 nm, 594 nm with 593 nm to 595 nm, 640 nm with 641 nm to 643 nm.
- The OBIS Galaxy Beam Combiner as tested and certified will be >60% power transmission per wavelength as measured with production tooling fixtures.
- Fiber connector output not compatible for patchcord-to-patchcord connection.
- M² measured with ModeMaster with 90/10 Clip Levels.

Utility and Environmental Requirements	
Dimensions	229 x 170 x 29 mm (9.0 x 6.7 x 1.1 in.)
Weight	1.4 kg (3 lbs.)
Shock Tolerance ¹ (g) (11 ms)	30
Vibration ¹ (g-RMS) (20 Hz to 2 kHz)	7.7
Ambient Temperature Operating Temperature Storage Temperature	10 to 50°C (50 to 122°F) ² -20 to 60°C (-4 to 140°F)
Laser Safety Classification ³	CLASS 4

- Notes:
1. Non-Operational with a before/after change of <10%.
 2. OBIS LS laser with Operating Temperature of 15 to 40°C (59 to 104°F).
 3. OBIS Galaxy is not a laser and therefore the Laser Safety Classification is determined by the end-user and application. Refer to CDRH 21 CFR 1040 subchapter J or IEC 60825-1.

Mechanical Specifications

OBIS Galaxy

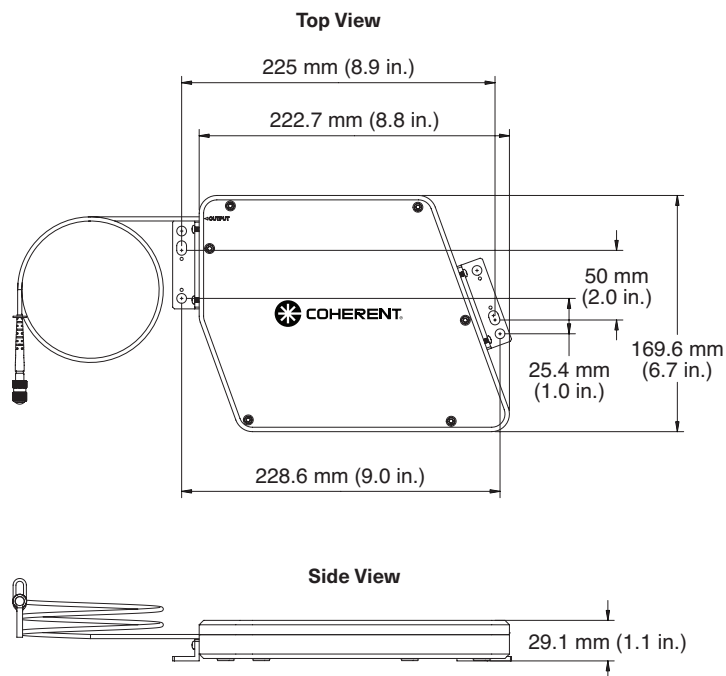
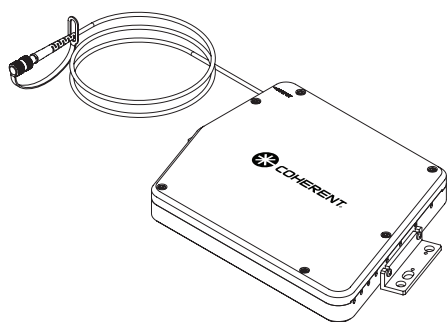

Mechanical Specifications

FC/APC Distal End - Output

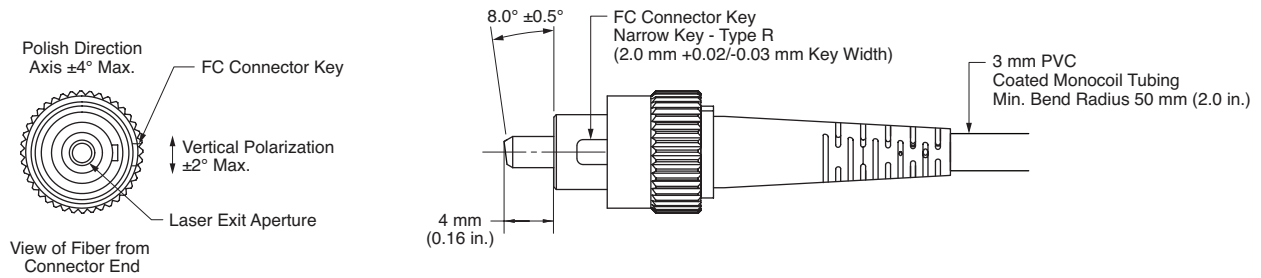

Optional FC/PC8 Angled Flat Connector Distal End – Output

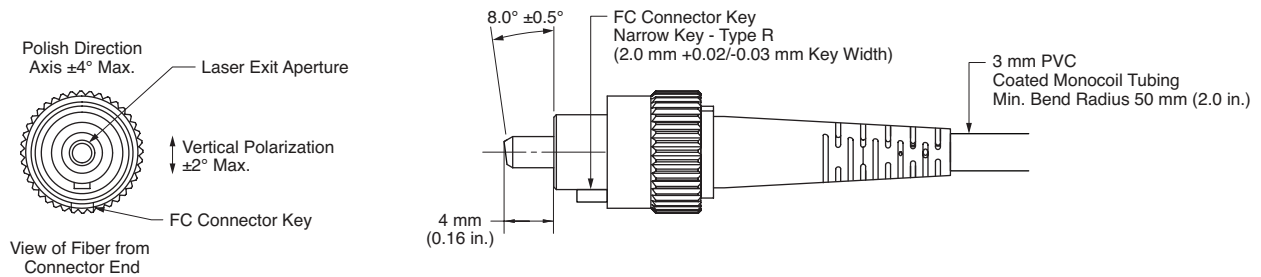

FC/UFC Launch End - Input

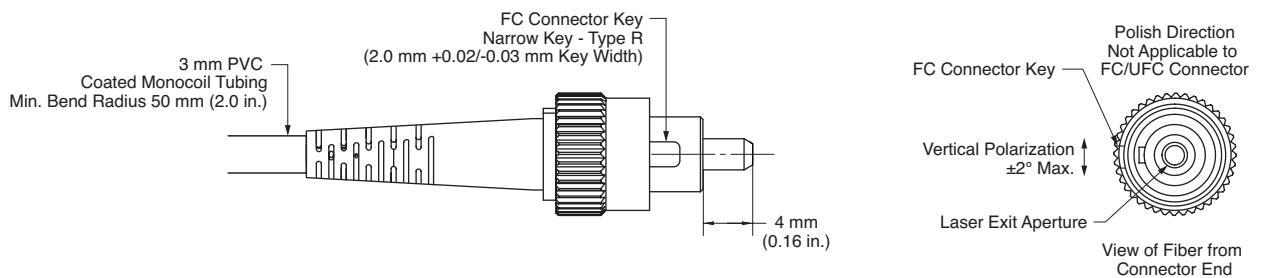

OBIS Galaxy Laser Combiner, Includes Output Fiber - Lasers sold separately	Part Number
8 Input FC/UFC, Single Output FC/APC, 405 nm, 458 nm, 488 nm, 514 nm, 532 nm, 561 nm, 594 nm, 640 nm	2261537
8 input FC/UFC, Single Output FC/PC8, 405 nm, 445 nm, 488 nm, 514 nm, 532 nm, 561 nm, 594 nm, 640 nm	1415671
8 input FC/UFC, Single Output FC/APC, 405 nm, 445 nm, 488 nm, 514 nm, 532 nm, 561 nm, 594 nm, 640 nm	1363484
8 input FC/UFC, Single Output FC/APC, 405 nm, 445 nm, 473 nm, 514 nm, 532 nm, 561 nm, 594 nm, 640 nm	1399474
OBIS FP LX Lasers ¹ for OBIS Galaxy	Part Number
OBIS 405 nm LX 50 mW Laser: Fiber Pigtail: UFC, Galaxy, 404 nm to 406 nm	1236438
OBIS 405 nm LX 100 mW Laser: Fiber Pigtail: UFC, Galaxy, 404 nm to 406 nm	1236439
OBIS 405 nm LX 200 mW Laser: Fiber Pigtail: UFC, Galaxy, 404 nm to 406 nm	2279120
OBIS 445 nm LX 45 mW Laser: Fiber Pigtail: UFC, Galaxy, 444 nm to 446 nm	1236441
OBIS 458 nm LX 45 mW Laser: Fiber Pigtail: UFC, Galaxy, 457 nm to 459 nm	1236442
OBIS 473 nm LX 50 mW Laser: Fiber Pigtail: UFC, Galaxy, 472 nm to 474 nm	1399476
OBIS 473 nm LX 150 mW Laser: Fiber Pigtail: UFC, Galaxy, 472 nm to 474 nm	2279124
OBIS 488 nm LX 30 mW Laser: Fiber Pigtail: UFC, Galaxy, 487 nm to 489 nm	1236443
OBIS 488 nm LX 100 mW Laser: Fiber Pigtail: UFC, Galaxy, 487 nm to 489 nm	1236444
OBIS 514 nm LX 50 mW Laser: Fiber Pigtail: UFC, Galaxy, 513 nm to 515 nm	1311150
OBIS 640 nm LX 75 mW Laser: Fiber Pigtail: UFC, Galaxy, 641 nm to 643 nm	1236445
OBIS 640 nm LX 130 mW Laser: Fiber Pigtail: UFC, Galaxy, 641 nm to 643 nm	2279132
OBIS FP LS Lasers ¹ for OBIS Galaxy	Part Number
OBIS 488 nm LS 150 mW Laser: Fiber Pigtail: UFC, Galaxy, 487 nm to 489 nm	2279128
OBIS 532 nm LS 80 mW Laser: Fiber Pigtail: UFC, Galaxy, 531 nm to 533 nm	1276599
OBIS 532 nm LS 150 mW Laser: Fiber Pigtail: UFC, Galaxy, 531 nm to 533 nm	2279130
OBIS 552 nm LS 80 mW Laser: Fiber Pigtail: UFC, Galaxy, 551.5 nm to 553.5 nm	1275619
OBIS 561 nm LS 80 mW Laser: Fiber Pigtail: UFC, Galaxy, 560.5 nm to 562.5 nm	1275608
OBIS 561 nm LS 150 mW Laser: Fiber Pigtail: UFC, Galaxy, 560.5 nm to 562.5 nm	2279131
OBIS 594 nm LS 60 mW Laser: Fiber Pigtailed: UFC, Galaxy, 592 nm to 594 nm	1363485

Notes:

- All OBIS Galaxy FP lasers same as standard OBIS FP lasers with the exception of ± 1 nm center wavelength tolerances and an ultra-flat contact FC/UFC termination with extended-life interface, anti-reflection (AR) coating on fiber tip.

NOTE: OBIS Galaxy Lasers include: laser and mounting hardware. The following needs to be ordered separately: OBIS LaserBox (part numbers 1228877 or 1343229), OBIS Remote (part number 1214875), or OBIS Heat Sink (part number 1193289). See OBIS LX/LS Family datasheet for details.

OBIS Galaxy Integrated Laser System

8-Wavelength, One Fiber Output Illumination System

The flexible and modular design of the OBIS Galaxy Integrated Laser System enables users to combine up to eight predetermined wavelength OBIS lasers into one fiber. Standard configurations are offered with three, four, or five OBIS lasers preloaded. Each can be expanded up to a total of eight lasers with the purchase of additional lasers. The output of the combined lasers is delivered through a 2-meter single-mode polarization maintaining fiber with an FC/APC connector.

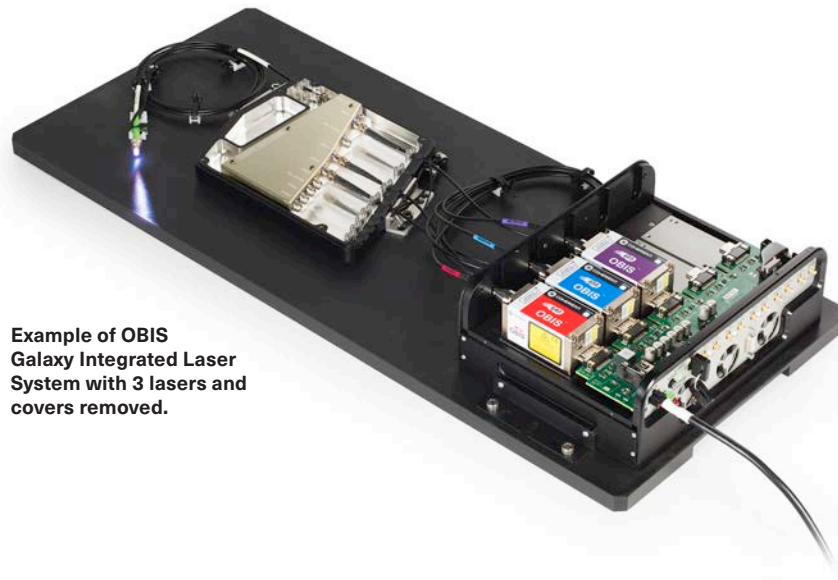

Example of OBIS Galaxy Integrated Laser System with 3 lasers and covers removed.

FEATURES

- Plug-and-play 8-input, singleoutput beam combiner
- Compact and low profile
- High-transmission beam combiner with typical 60% throughput per channel
- Fiber FC/APC output connector, optional FC/PC8

APPLICATIONS

- Optogenetics
- Endoscopy
- Microscopy
- Cytometry
- Genomics

OBIS Galaxy Integrated Laser System



Example of Laser Box with 5 lasers loaded. Cover removed. Purchase a second Laser Box for applications requiring 6-10 lasers total.



OBIS Galaxy Beam Combiner. 8 fiber input connectors, one combined output in a 2-meter fiber with FC/PC8 or FC/APC connector. Example shown is 3 lasers with cover removed.

OBIS Galaxy Integrated Laser System

OBIS Galaxy Integrated System

The OBIS Galaxy Integrated System is assembled, tested, and shipped on a 711 x 305 mm (28 x 12 inch) plate. Add additional OBIS Galaxy lasers (sold separately) to increase your system capabilities.

Example of 3-Laser Galaxy with covers installed and power supply.



OBIS Galaxy Integrated Laser System

Three-Laser Galaxy Integrated Laser System. Assembled and Tested as a Turn-key System.	Part Number
<p>As a turnkey configuration the OBIS Galaxy Laser Combining System includes:</p> <ol style="list-style-type: none">1. OBIS 405 nm LX 50 mW Fiber Pigtailed Galaxy Laser, FC/UFC2. OBIS 488 nm LX 30 mW Fiber Pigtailed Galaxy Laser, FC/UFC3. OBIS 640 nm LX 75 mW Fiber Pigtailed Galaxy Laser, FC/UFC4. OBIS Galaxy, compatible with 405 nm, 445 nm, 488 nm, 514 nm, 532 nm, 561 nm, 594 nm, 640 nm<ol style="list-style-type: none">a. Includes 2 meter output fiber with FC/APC Connector5. Laser Box, 5-mounting bays (with 50 Ohm Digital Modulation Impedance)<ol style="list-style-type: none">a. Includes power supply and control software6. System pre-assembled, tested, and mounted onto system plate	1311750

3-Laser Galaxy Integrated Laser System shown with covers removed on the Galaxy and Laser Box. Unit ships with covers and power supply.



OBIS Galaxy Integrated Laser System

Three-Laser Galaxy Integrated Laser System. Assembled and Tested as a Turn-key System.	Part Number
As a turnkey configuration the OBIS Galaxy Laser Combining System includes: 1. OBIS 488 nm LX 100 mW Fiber Pigtailed Galaxy Laser, FC/UFC 2. OBIS 561 nm LX 80 mW Fiber Pigtailed Galaxy Laser, FC/UFC 3. OBIS 640 nm LX 75 mW Fiber Pigtailed Galaxy Laser, FC/UFC 4. OBIS Galaxy, compatible with 405 nm, 445 nm, 488 nm, 514 nm, 532 nm, 561 nm, 594 nm, 640 nm a. Includes 2 meter output fiber with FC/APC Connector 5. Laser Box, 5-mounting bays (with 2000 Ohm Digital Modulation Impedance) a. Includes power supply and control software 6. System pre-assembled, tested, and mounted onto system plate	1451749

3-Laser Galaxy Integrated Laser System shown with covers removed on the Galaxy and Laser Box. Unit ships with covers and power supply.



OBIS Galaxy Integrated Laser System

Four-Laser Galaxy Integrated Laser System. Assembled and Tested as a Turn-key System.	Part Number
As a turnkey configuration the OBIS Galaxy Laser Combining System includes: 1. OBIS 488 nm LX 100 mW Fiber Pigtailed Galaxy Laser, FC/UFC 2. OBIS 532 nm LS 80 mW Fiber Pigtailed Galaxy Laser, FC/UFC 3. OBIS 594 nm LS 60 mW Fiber Pigtailed Galaxy Laser, FC/UFC 4. OBIS 640 nm LX 75 mW Fiber Pigtailed Galaxy Laser, FC/UFC 5. OBIS Galaxy, compatible with 405 nm, 445 nm, 488 nm, 514 nm, 532 nm, 561 nm, 594 nm, 640 nm a. Includes 2 meter output fiber with FC/APC Connector 6. Laser Box, 5-mounting bays (with 2000 Ohm Digital Modulation Impedance) a. Includes power supply and control software 7. System pre-assembled, tested, and mounted onto system plate	1446060

4-Laser Galaxy Integrated Laser System shown with covers removed on the Galaxy and Laser Box. Unit ships with covers and power supply.

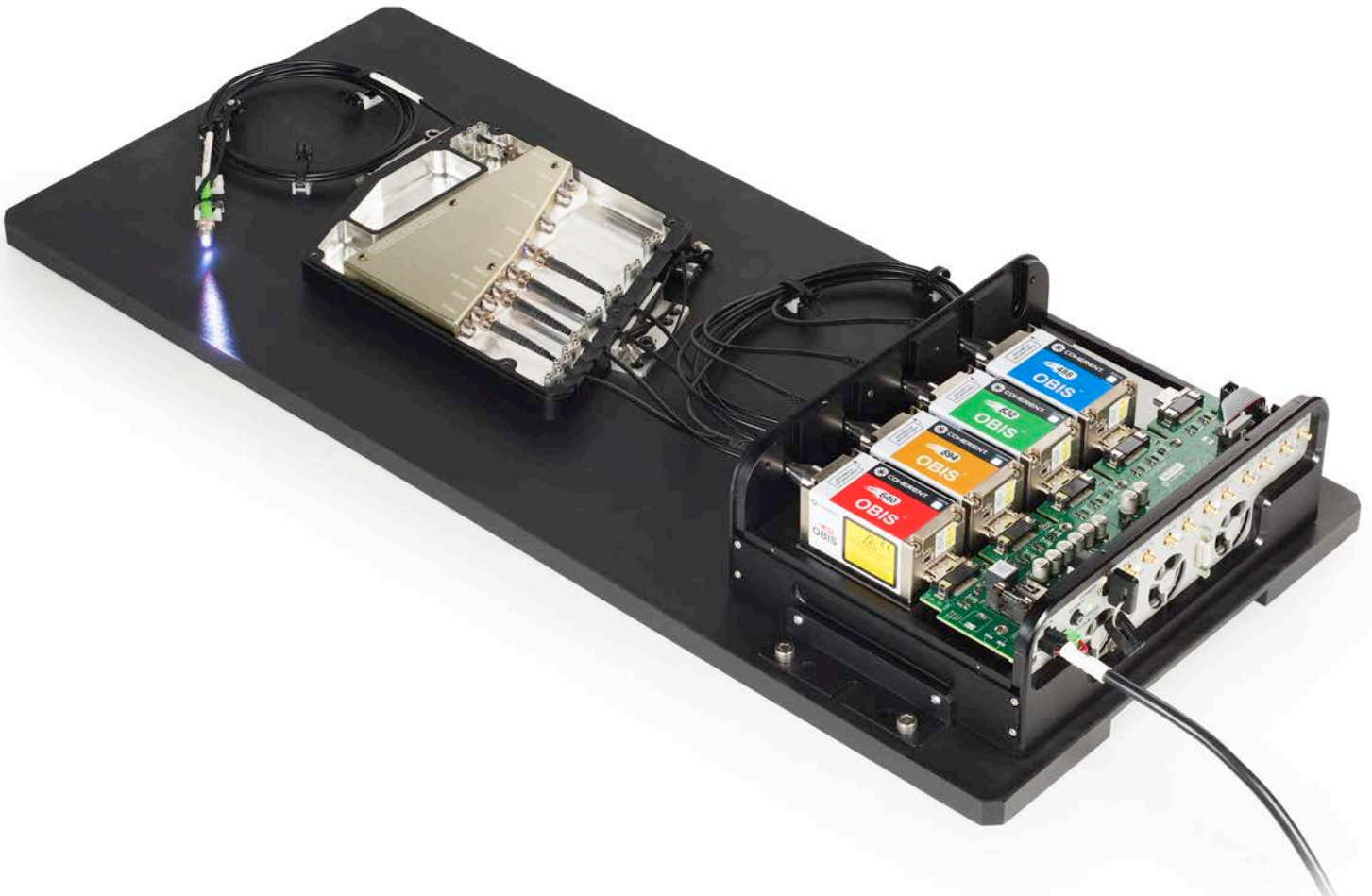

OBIS Galaxy Integrated Laser System

Five-Laser Galaxy Integrated Laser System. Assembled and Tested as a Turn-key System.	Part Number
As a turnkey configuration the OBIS Galaxy Laser Combining System includes: 1. OBIS 488 nm LX 100 mW Fiber Pigtailed Galaxy Laser, FC/UFC 2. OBIS 532 nm LS 80 mW Fiber Pigtailed Galaxy Laser, FC/UFC 3. OBIS 561 nm LS 80 mW Fiber Pigtailed Galaxy Laser, FC/UFC 4. OBIS 594 nm LS 60 mW Fiber Pigtailed Galaxy Laser, FC/UFC 5. OBIS 640 nm LX 75 mW Fiber Pigtailed Galaxy Laser , FC/UFC 6. OBIS Galaxy, compatible with 405 nm, 445 nm, 488 nm, 514 nm, 532 nm, 561 nm, 594 nm, 640 nm a. Includes 2 meter output fiber with FC/APC Connector 7. Laser Box, 5-mounting bays (with 2000 Ohm Digital Modulation Impedance) a. Includes power supply and control software 8. System pre-assembled, tested, and mounted onto system plate	2252231

5-Laser Galaxy Integrated Laser System shown with covers removed on the Galaxy and Laser Box. Unit ships with covers and power supply.



OBIS Galaxy Integrated Laser System

Specifications ¹	OBIS Galaxy Laser Combiner for the Integrated System
Power Throughput ² (%) for 405 nm to 590 nm for 640 nm	>45, Typical >60 >55, Typical >70
Maximum Total Output Power (mW)	<500
RMS Noise (%) (20 Hz to 2 MHz)	<0.5
Peak-to-Peak Noise (%) (20 Hz to 20 kHz)	<2
Fiber Connector Type (Input Connectors)	FC form-factor, ultra-flat contact FC/UFC with extended-life interface, anti-reflection (AR) coated tip
Polarization Extinction Ratio Loss (%)	<50
Long-Term Power Throughput (%) (8 hours, ±8°C)	>95
Long-Term Power Throughput (%) (average)	≤2 over 1000 hours
Output Fiber	
Fiber Connector Type ³ (distal end), FC/APC	8° angled, with extended-life interface
Fiber Cable Type	3 mm mono-coil
Fiber Cable Length (m) (minimum)	2
Fiber Numerical Aperture (NA) (1/e ²)	0.055
Mode Field Diameter (μm) (typical)	3
Spatial Mode	TEM ₀₀
M ² (Beam Quality) ⁴	≤1.1
Fiber Minimum Bend Radius	51 mm (2.0 in.)
Fiber Tensile Load (maximum)	1 kg (2.2 lbs.)

Notes:

1. System specifications measured at 25°C.
2. The OBIS Galaxy Beam Combiner as tested and certified will be >60% power transmission per wavelength as measured with production tooling fixtures.
3. Fiber connector output not compatible for patchcord-to-patchcord connection.
4. M² measured with ModeMaster with 90/10 Clip Levels.

OBIS Galaxy Integrated Laser System

Utility and Environmental Requirements	
Dimensions	229 x 170 x 29 mm (9.0 x 6.7 x 1.1 in.)
Weight	1.4 kg (3 lbs.)
Shock Tolerance ¹ (g) (11 ms)	30
Vibration ¹ (g-RMS) (20 Hz to 2 kHz)	7.7
Ambient Temperature Operating Temperature Storage Temperature	10 to 50°C (50 to 122°F) ² -20 to 60°C (-4 to 140°F)
Laser Safety Classification ³	CLASS 4

Notes:

1. Non-Operational with a before/after change of <10%.
2. OBIS LS laser with Operating Temperature of 15 to 40°C (59 to 104°F).
3. Class 4 laser product IEC 60825-1 (2007), OEM component, does not comply with 21 CFR 1040.10 and 1040.11.

Mechanical Specifications

OBIS Galaxy

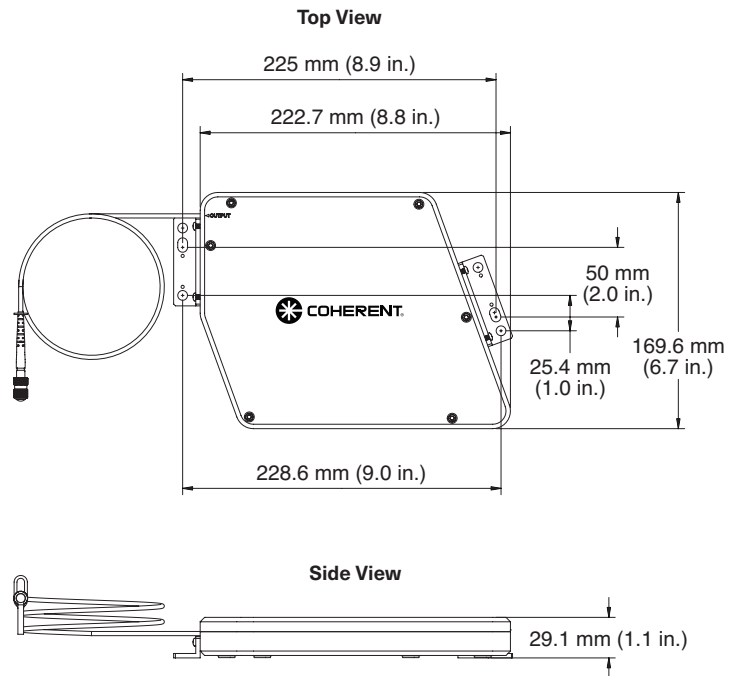
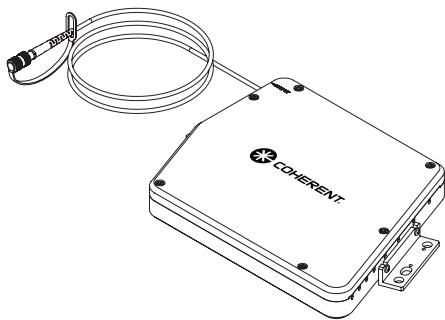

Mechanical Specifications

OBIS Laser Box

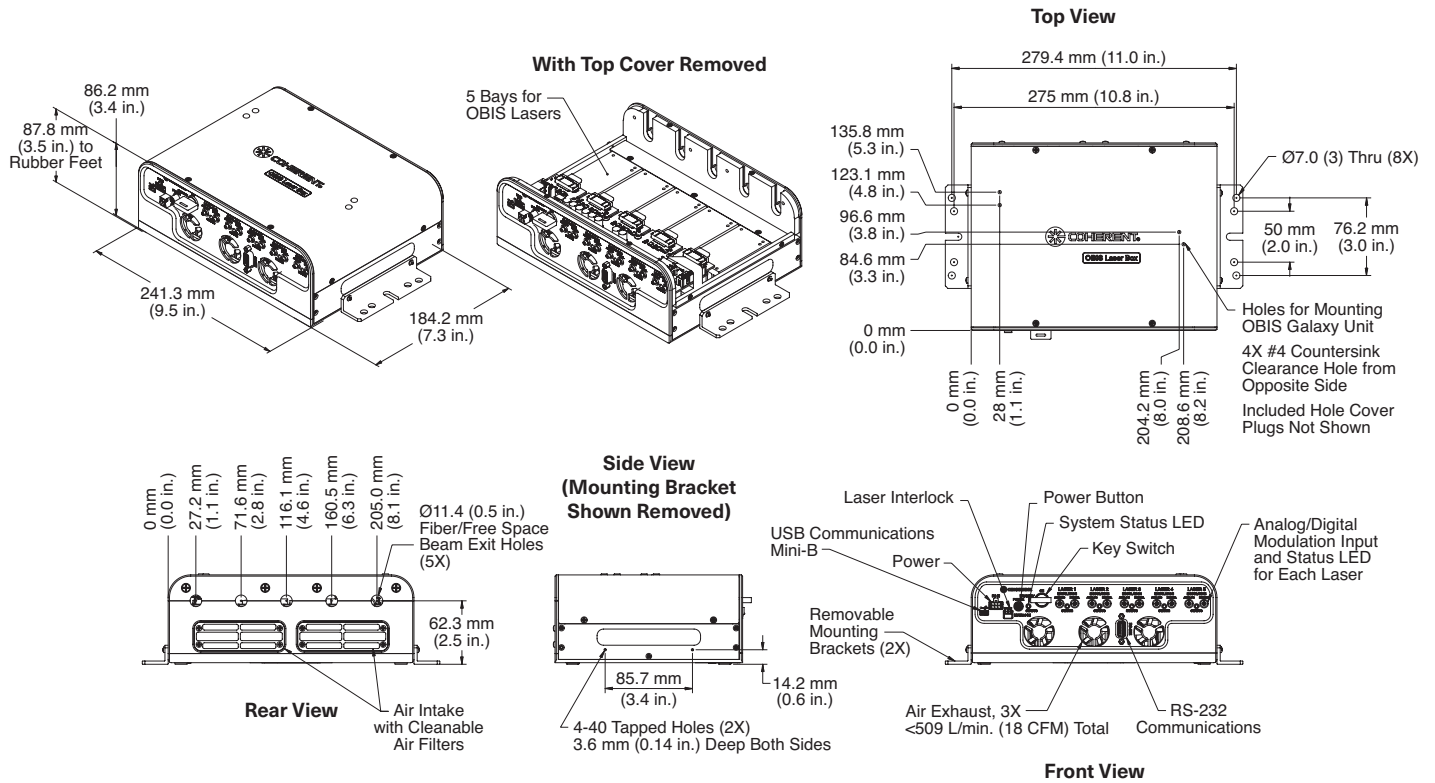

FC/APC Distal End - Output

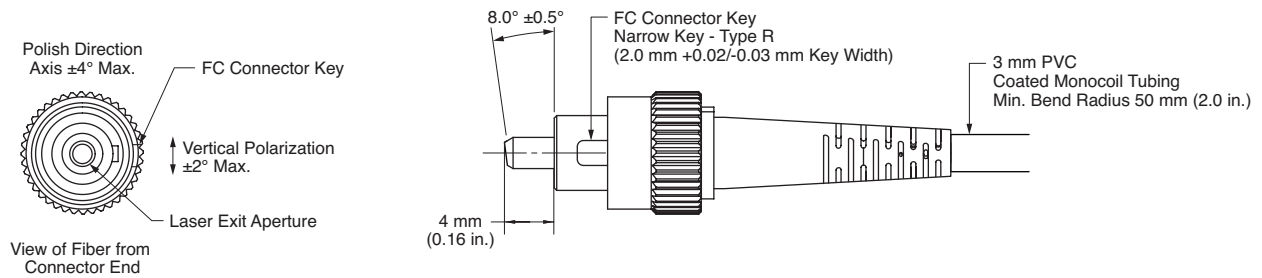

OBIS Galaxy Integrated Laser System

OBIS Galaxy Laser Combiner, Includes Output Fiber - Lasers sold separately	Part Number
8 Input FC/UFC, Single Output FC/APC, 405 nm, 458 nm, 488 nm, 514 nm, 532 nm, 561 nm, 594 nm, 640 nm	2261537
8 input FC/UFC, Single Output FC/PC8, 405 nm, 445 nm, 488 nm, 514 nm, 532 nm, 561 nm, 594 nm, 640 nm	1415671
8 input FC/UFC, Single Output FC/APC, 405 nm, 445 nm, 488 nm, 514 nm, 532 nm, 561 nm, 594 nm, 640 nm	1363484
8 input FC/UFC, Single Output FC/APC, 405 nm, 445 nm, 473 nm, 514 nm, 532 nm, 561 nm, 594 nm, 640 nm	1399474
OBIS FP LX Lasers ¹ for OBIS Galaxy	Part Number
OBIS 405 nm LX 50 mW Laser: Fiber Pigtail: UFC, Galaxy, 404 nm to 406 nm	1236438
OBIS 405 nm LX 100 mW Laser: Fiber Pigtail: UFC, Galaxy, 404 nm to 406 nm	1236439
OBIS 405 nm LX 200 mW Laser: Fiber Pigtail: UFC, Galaxy, 404 nm to 406 nm	2279120
OBIS 445 nm LX 45 mW Laser: Fiber Pigtail: UFC, Galaxy, 444 nm to 446 nm	1236441
OBIS 458 nm LX 45 mW Laser: Fiber Pigtail: UFC, Galaxy, 457 nm to 459 nm	1236442
OBIS 473 nm LX 50 mW Laser: Fiber Pigtail: UFC, Galaxy, 472 nm to 474 nm	1399476
OBIS 473 nm LX 150 mW Laser: Fiber Pigtail: UFC, Galaxy, 472 nm to 474 nm	2279124
OBIS 488 nm LX 30 mW Laser: Fiber Pigtail: UFC, Galaxy, 487 nm to 489 nm	1236443
OBIS 488 nm LX 100 mW Laser: Fiber Pigtail: UFC, Galaxy, 487 nm to 489 nm	1236444
OBIS 514 nm LX 50 mW Laser: Fiber Pigtail: UFC, Galaxy, 513 nm to 515 nm	1311150
OBIS 640 nm LX 75 mW Laser: Fiber Pigtail: UFC, Galaxy, 641 nm to 643 nm	1236445
OBIS 640 nm LX 130 mW Laser: Fiber Pigtail: UFC, Galaxy, 641 nm to 643 nm	2279132
OBIS FP LS Lasers ¹ for OBIS Galaxy	Part Number
OBIS 488 nm LS 150 mW Laser: Fiber Pigtail: UFC, Galaxy, 487 nm to 489 nm	2279128
OBIS 532 nm LS 80 mW Laser: Fiber Pigtail: UFC, Galaxy, 531 nm to 533 nm	1276599
OBIS 532 nm LS 150 mW Laser: Fiber Pigtail: UFC, Galaxy, 531 nm to 533 nm	2279130
OBIS 561 nm LS 80 mW Laser: Fiber Pigtail: UFC, Galaxy, 560.5 nm to 562.5 nm	1275608
OBIS 561 nm LS 150 mW Laser: Fiber Pigtail: UFC, Galaxy, 560.5 nm to 562.5 nm	2279131
OBIS 594 nm LS 60 mW Laser: Fiber Pigtailed: UFC, Galaxy, 592 nm to 594 nm	1363485

Notes:

- All OBIS Galaxy FP lasers same as standard OBIS FP lasers with the exception of ± 1 nm center wavelength tolerances and an ultra-flat contact FC/UFC termination with extended-life interface, anti-reflection (AR) coating on fiber tip.

NOTE: OBIS Galaxy Lasers include: laser and mounting hardware. The following needs to be ordered separately: OBIS LaserBox (part numbers 1228877 or 1343229), OBIS Remote (part number 1214875), or OBIS Heat Sink (part number 1193289). See OBIS LX/LS Family datasheet for details.